

MAXXUM 80T
80 lbs Thrust
24 Volt 56 Amps
42" SHAFT

for use with "WWAF" serial numbers
3-year warranty from the date of purchase

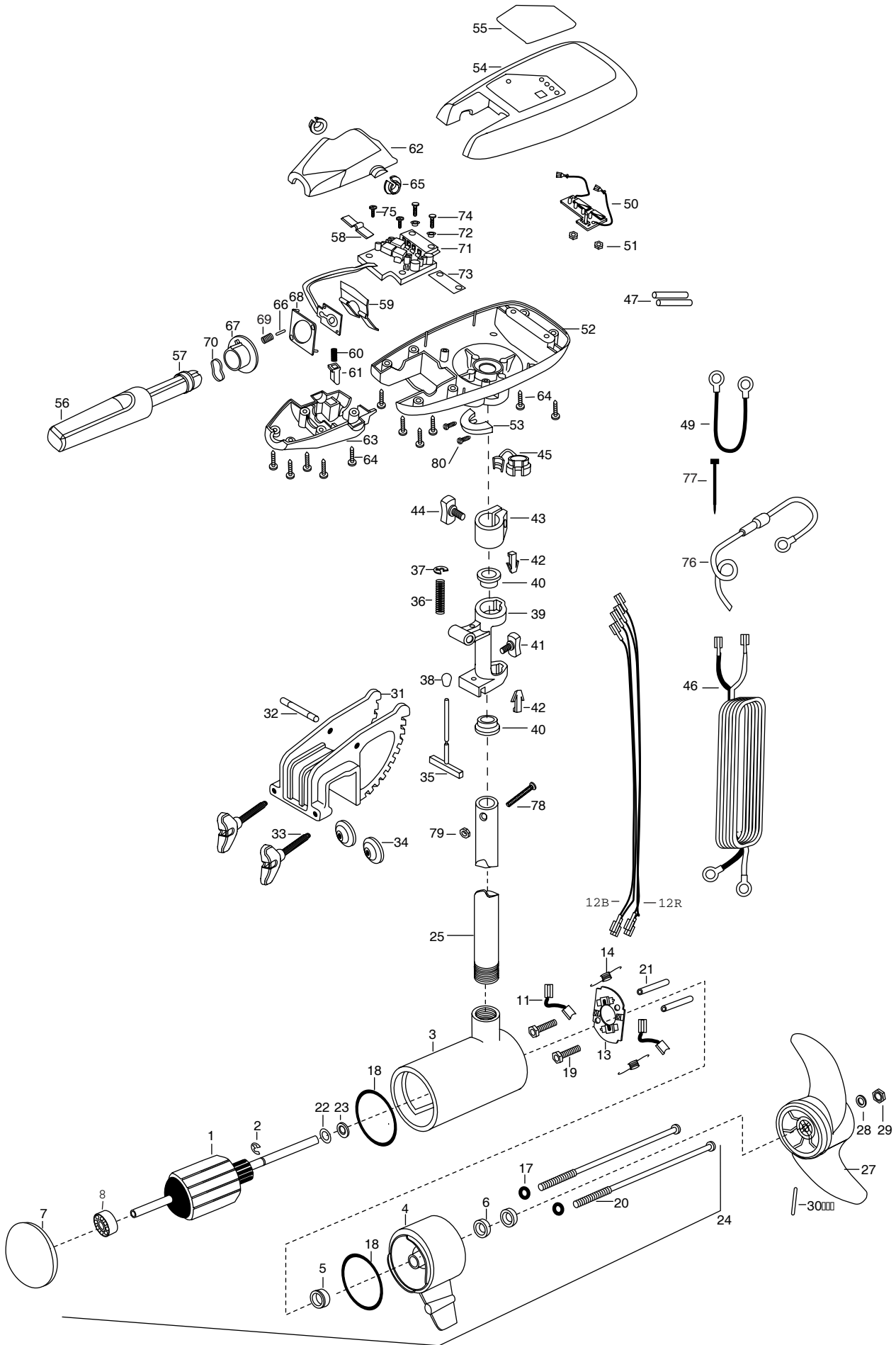

1	2-100-213	ARMATURE ASSEMBLY 24V 4 "	*33	2061300	SCREW-CLAMP [2.EA]	66	2302600	PIN- ACTUATOR
2	788-040	RETAINING RING	*34	2011710	WASHER-CLAMP SCREW [2.EA]	67	2302850	ACTUATOR- CAM
3	431-160	HOUSING ASSEMBLY CENTER 4.0 TXT	35	2033600	T-BAR	68	2302851	ACTUATOR- FWD/REV
4	2-300-160	BRUSH END HOUSING ASSEMBLY	36	2012700	SPRING-T-BAR	69	2302740	SPRING- ACTUATOR
5	144-017	BEARING- FLANGE	37	2013000	E-RING	70	2302741	SPRING- CAM
6	880-025	SEAL [2.EA]	38	2010100	KNOB-TILT	71	2344006	CONTROL BOARD W/O LEAD- 24V
7	421-260	PLAIN END HOUSING ASSEMBLY	39	2031852	HINGE	72	2301710	WASHER- INSUL.TRANSFER BAR
8	140-010	BALL BEARING	40	2037300	BUSHING-HINGE [2.EA]	73	2365105	INSULATOR PAD
11	186-094	BRUSH 4" [2.EA]	41	2011385	SCREW-TENSION W/NEW KNOB	74	2372100	SCREW -8-18 X 5/8 SS [2.EA]
12B	640-014	LEADWIRE BLACK 10 AWG 55	42	2062800	TENSION BLOCK [2.EA]	75	2301310	SCREW- 8-18 X 1/2 SS [2.EA]
12R	640-119	LEADWIRE RED 10 AWG 56-1/2	43	2061520	COLLAR-DEPTH ENDURA	76	2060310	GROUND WIRE- FUSED
13	738-004	BRUSH PLATE- 4"	44	2011365	SCREW-COLLAR W/NEW KNOB	77	2256300	TIE WRAP 5.5"
14	975-041	SPRING- TORSION [2.EA]	45	2052900	STRAIN RELIEF	78	2383407	SCREW 10-24X 2
17	701-009	O-RING- THRU BOLT [2.EA]	46	2050609	LEADWIRE- 10 GA.	79	2383124	NUT HEX 10-24 NYLOCK
18	701-043	O-RING [2.EA]	47	2375400	SHRINK TUBE [2.EA]	80	2263434	SCREW #8 X 1" PPH SS [2.EA]
19	830-027	SCREW- SELF THREAD 10-32X2 [2.EA]	49	2340610	CONNECTOR CABLE 12"			
20	830-094	THRU BOLT 12 24X 10.31 [2.EA]	50	2034036	BATTERY GAUGE- 24V. /4 LED			
21	973-025	SPACER- BRUSHPLATE [2.EA]	51	2303120	SPEED NUT [2.EA]			
22	990-051	WASHER- STEEL THRUST	52	2062592	CONTROL BOX FW			
23	990-052	WASHER- NYLATRON	53	2061515	COLLAR- CONTROL BOX			
24	2316236	MOTOR ASSEMBLY 24V VARS TXT 4"	54	2990294	COVER- CNTRL BOX/DECAL ASSMBLY			
25	2032057	TUBE COMPOSITE 36"	55	2065662	DECAL- COVER 80T			
	2032053	TUBE COMPOSITE 42"	56	2990914	HANDLE ASSEMBLY W/O U-JOINT			
■	1378132	PROPELLER KIT	57	2060000	BEARING- HANDLE [2.EA]			
27	2331160	PROPELLER	58	2302742	SPRING- DETENT OFF SS			
28	2091701	WASHER- PROP LARGE	59	2302743	SPRING- DETENT HANDLE-TILT			
29	2093101	NUT- PROP NYLOC	60	2302745	SPRING- RELEASE BUTTON SS			
30	2262658	PIN- DRIVE	61	2303720	RELEASE BUTTON- HANDLE			
■	2991960	BRACKET/HINGE ASSEMBLY INCL. 31-42	62	2060409	HANDLE- TOP HALF			
■	2771901	BRACKET ASSEMBLY INCL. 31, 33,-34	63	2060415	HANDLE- LOWER HALF			
*31	2031901	BRACKET	64	2303412	SCREW-6-20 X 5/8 SELF TAP [11.EA]			
32	2010511	PIN-HINGE	65	2060005	BEARING- HANDLE PIVOT			

BLACK

CONTROL BOARD

BATTERY METER

BLACK

RED

POT BOARD

RED

BLACK

CONNECTING WIRE

RED

