

VANTAGE 55  
55 LBS THRUST  
12 VOLT 45 AMPS

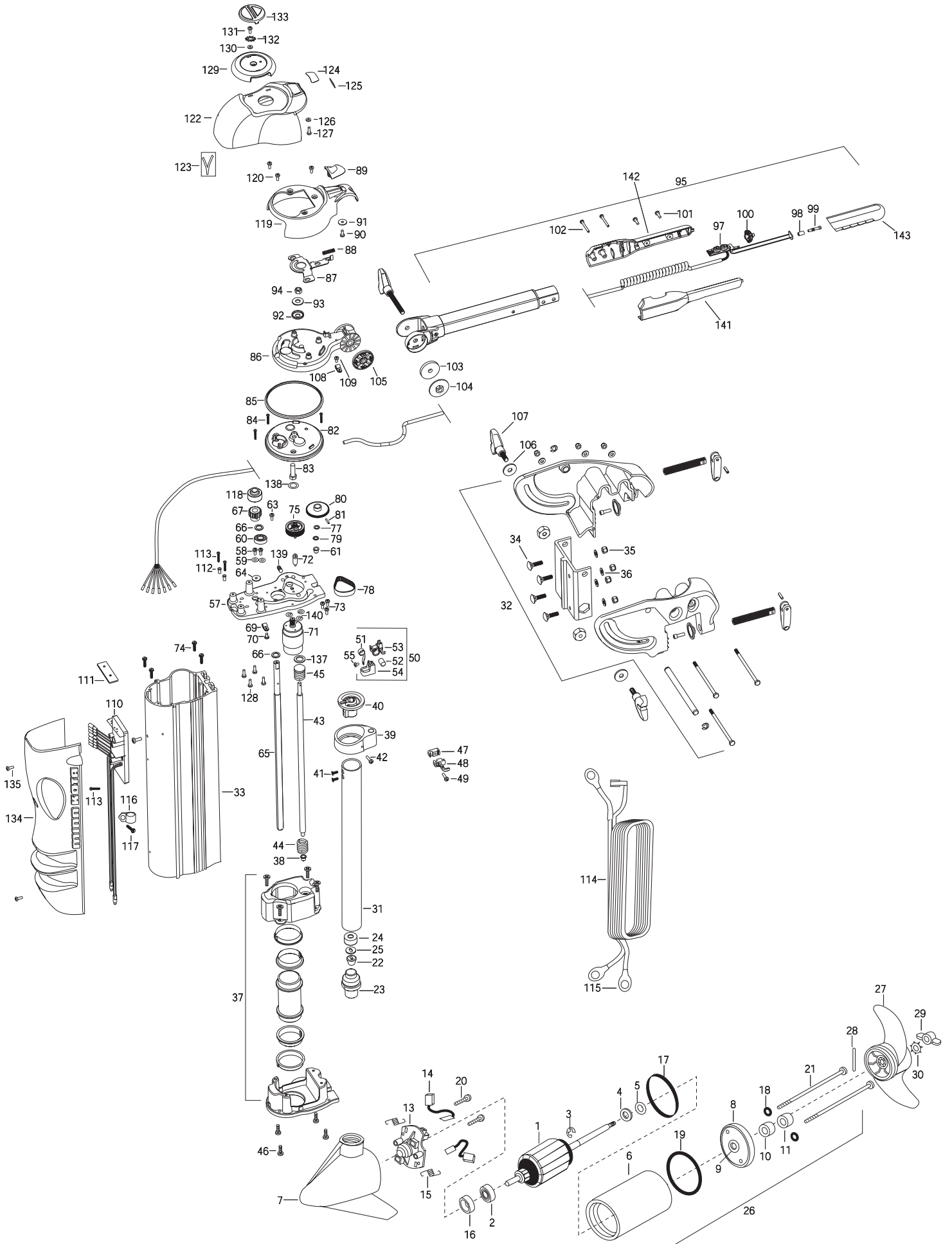

1	2-100-013	ARMATURE ASSEMBLY 12V 3.625" FW #55	48	2053205	WIRE CLAMP, RIGHTHAND	100	2050111	KNOB-SPEED CONTROL
2	140-010	BEARING- BALL	49	2053417	SCREW-10-16X3/4" TYPE BT,PPH	101	2012100	SCREW-8-18X5/8" THD CUT(2 REQ'D)
3	788-015	RETAINING RING	50	2990400	TAPE SPRING ASSEMBLY (VANTAGE	102	2053412	SCREW 8 X1.5" TYPE 25 (2 REQ'D)
4	990-067	WASHER- STEEL THRUST	51	2052705	SPRING, CONSTANT FORCE	103	2051736	WASHER-SPACER ID.4XOD 1
5	990-070	WASHER- NYLATRON	52	2052610	PIN-PIVOT 7/16" O.D.	104	2053115	NUT-WASHER HANDLE ASSEMBLY
6	431-101	CENTER HOUSING ASSEMBLY 3.62 FW	53	2051920	BRACKET-SPRING	105	2050015	RACHET-DISK HANDLE ASSEMBLY
7	421-065	BRUSH END HOUSING	54	2052305	WIRE GUIDE (VANTAGE)	106	2051737	WASHER-FLAT ID.406XOD.8
8	2-400-101	PLAIN END HOUSING ASSEMBLY 3.62	55	2053418	SCREW-#4-40X1/4" TYPE F,PPH	107	2050921	HANDLE, TENSION, LONG
9	144-049	BEARING- FLANGE	57	2991927	TOP PLATE/BEARING ASSEMBLY	108	2052510	CABLE CLAMP 3/16" (2 REQ'D)
10	880-003	**SEAL	58	2053414	SCREW-#8-32X1/2" TRI-LOBE(2 REQ'D)	109	2053415	SCREW-8-32X3/8" TRI-LOBE (3 REQ'D)
11	880-006	**SEAL W/SHIELD	59	2051717	WASHER- #8 SAE FLAT (2 REQ'D)	110	2054035	CNTRL BOARD ASSEMBY,12V-MAIN
13	738-036	BRUSH PLATEW/HOLDER	60	2057306	BEARING-BALL (VANTAGE)	111	2315105	INSULATING PAD
14	186-036	BRUSH (2 REQ'D)	61	2057302	BEARING-UPPER, LIFT SCREW	112	2261712	WASHER-SHOULDER MAX (2 REQ'D)
15	975-040	SPRING - TORSION (2 REQ'D)	63	2053415	SCREW-#8-32X3/8 TRI-LOBE	113	2053407	SCREW-#8-32 X .75 PPH (3 REQ'D)
16	725-050	BRUSH RETENTION- PAPER TUBE	64	2051716	WASHER-FENDER #10	114	2051225	LEADWIRE, 12V, 3 CONDUCTOR
17	337-036	**GASKET	65	2052001	SHAFT-STEERING, VANTAGE	115	2020700	TERMINAL RING, 3/8" (2 REQ'D)
18	701-008	**O-RING- THRU BOLT (2 REQ'D)	66	2051706	WASHER-SPRING SUPPORT (2 REQ'D)	116	2052512	CABLE CLAMP, 1/2" VANTAGE
19	701-081	**O-RING (2 REQ'D)	67	2052205	GEAR, STEERING TUBE MACHINED	117	2053415	SCREW-#8-32 X 3/8" TRI-LOB
20	830-007	SCREW #8-32 (2 REQ'D)	69	2052510	CABLE CLAMP,3/16" VANTAGE	118	2052210	ROLLER-STEERING SHAFT
21	830-042	THRU BOLT 10-32 X 8.83 (2 REQ'D)	70	2053415	SCREW-#8-32 X 3/8" TRI-LOBE	119	2050200	COVER-CONTROL HEAD
22	1389-015	GROMMET - STRAIN RELIEF	71	2057801	MOTOR-LIFT (12/24,36V) VANTAGE	120	2053415	SCREW-8-32 X 3/8" T-LOBE(3 REQ'D)
23	979-015	STRAIN RELIEF - BODY	72	2058411	TENSIONER-BELT (VANTAGE)	121	2012100	SCREW-8-18 X 5/8" THD (3 REQ'D)
24	979-016	CAP - STRAIN RELIEF	73	2053422	SCREW - M3 .5X10 PPH ZPS (3 REQ'D)	122	2050210	SHROUD-CONTROL HEAD
25	990-015	WASHER - MTR SEAL	74	2053413	SCREW-10-16X1" TYPE AB,HEX(4 REQ'D)	123	2055612	DECAL-SHROUD (VNTGE) (2 REQ'D)
26	2099071	MOTOR ASSEMBLY 3.625 12V VARS FW	75	2772202	CLUSTER GEAR ASSEMBLY	124	2055603	DECAL-COVER, 12V 55#
■	1378122	PROPELLER KIT	77	2051703	WASHER-THRUST ID.315 OD.562	125	2055610	DECAL-COVER LED
27	2091150	PROPELLER (W.WEDGE)T PROS	78	2050800	BELT-DRIVE (VANTAGE)	126	2051712	WASHER- BULB .152 ID.50 OD .06
28	2092600	PIN-DRIVE SS	79	2051705	WASHER-NYLON ID.312	127	2302100	SCREW-6-20X1/2" THD CUT
29	2053101	NUT- NYLOC 5/16 STD SS	80	2990426	LIFT GEAR ASSEMBLY	128	2012100	SCREW-8-18X5/8" THD (4 REQ'D)
30	2151726	WASHER- 5/16 STD SS	81	2052620	PIN-DRIV-LOK 1/8X5/8"	129	2050110	KNOB-POINTER, VANTAGE
31	2052010	TUBE-MOTOR, 1-3/4"	82	2996515	GEAR HOUSING/BEARING ASSEMBLY	130	2051717	WASHER-FOR #8 SCREW
32	2991820	TRANSOM BRACKET ASSEMBLY	83	2383500	BOLT-3/8-16 X1.25	131	2332101	SCREW-8-32X1/2" SS
33	2056505	HOUSING EXTRUSION, MACHINE	84	2053402	SCREW-10-24X1" TRI-LOBE(3 REQ'D)	132	2371715	LOCKWASHER-STAR #8 ZINC
34	2053511	BOLT-CARRIAGE 5/16-18 1" (4 REQ'D)	85	2054600	O-RING, GEAR HOUSING	133	2056700	PLUG, POINTER, VANTAGE
35	2151726	WASHER-5/16 STD SS (4 REQ'D)	86	2056510	CAP-UPPER, GEAR HOUSING	134	2050220A	SHIELD-EXTRUSION, VANTAGE 12V
36	2053103	NUT, 5/16-18 NYLOC (4 REQ'D)	87	2057200	LATCH (VANTAGE)	135	2053414	SCREW-#8-32X1/2" TRI-L (2 REQ'D)
37	2990420	LOWER SUPPORT CAGE ASSEMBLY	88	2052711	SPRING, LATCH RETURN	136	2055611	DECAL-SHIELD (VANTAGE)
38	2057302	BEARING-UPPER, LIFT SCREW	89	2050102	KNOB-LATCH (VANTAGE)	137	2151726	WASHER- 5/16 STD SS
39	2051510	YOKE-LIFT SCREW	90	2353401	SCREW-10-16 X1/2" STALGDT	138	2051732	WASHER- ID.195X.278
40	2056200	BEARING RACE-YOKE	91	2051716	WASHER-FENDER #10	139	2053420	SET SCREW- #8-32X1/4
41	2053401	SCREW-10X1/2" TYPE 25 2 REQ'D)	92	2151730	WASHER-CUP (HINGE BRACKET)	140	2051710	LOCKWASHER- SPLIT 3MM (3 REQ'D)
42	2353401	SCREW-10-16X1/2" STALGD	93	2051737	WASHER-.406XOD.875 FLAT (ZINC)	■	2880910	HANDLE L/R KIT
43	2053400	SCREW-LIFT 1/2-10 ACME	94	2053107	NUT-3/8-16", TOPLOCK			INCL. 100,101,102,141,142,143
44	2052707	SPRING-COIL SOFT STOP	95	2990950	HANDLE/CTRL BOARD ASSEMBLY	*141	2050911	HANDLE SIDE LEFT
45	2990429	COIL SPRING/WASHER ASSEMBLY	97	2994005	CTRL BOARD ASSEMBLY-HANDLE	*142	2050916	HANDLE SIDE RIGHT
46	2053413	SCREW-10-16X1" TYPE AB,HEX (4 REQ'D)	98	2055115	BUTTON SWITCH ACTUATOR	143	2880424	GRIP KIT
47	2053200	WIRE CLAMP, LEFTHAND	99	2053700	PLUNGER- ON/OFF			

**\*\*Seal & Oring Kit P/N 2888460**

\* This item is part of an assembly. This item cannot be sold separately due to machining and /or assembly that is required.

P/N 2054904 REV.B 1-02

# VANTAGE 55 12V

